

Series 8000 measuring bale of pulp as it is being pressed.

ONLY FORTÉ MEASURES MOISTURE IN THE WHOLE BALE

A Forté Moisture Measurement System will increase your profits instantly. Forté Moisture Measurement Systems provide immediate % Air-Dry invoice data.

From measuring moisture and providing accurate production records to bale marking and dryer control,

Forté Pulp Systems do it all!



Finishing line schematic for a two-line Forté Series 8762 System.

The upper portion of the screen allows the user to see the position of each bale on the finishing line. Bales can easily be removed with the click of a mouse.

Stocks and Grades can be selected from combo boxes. Lot Size, Bale Count, Current Lot, and Next Lot are displayed in a text box. Bale Count, up or down, is also presented in large numerals to enable viewing from a distance.

*Screen images are user-configurable and may look different on your computer.

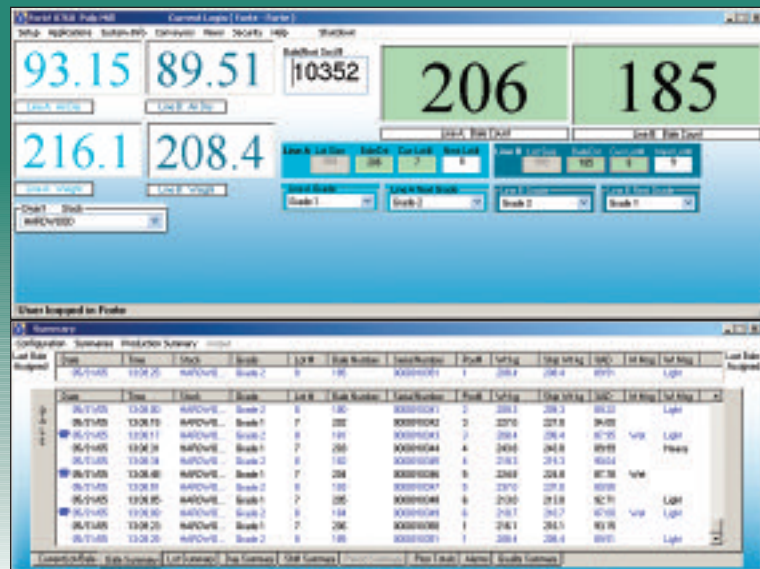

A Console view for a two-line Forté Series 8762 System.

The large character, user-selectable displays in the top left corner show the % Air-Dry and the Weight of current bales. Operators can adjust Bale Serial Numbers and next Lot Number subject to Password Controls. New programs have multiple levels of user access rights.

Production Record summary totals are displayed by bale, by lot, by shift, by day, or by a user set periodic time interval. Tabs at the bottom of the screen allow selection of all summary types.

The bottom section of these screens show Production Data. Displayed fields are user-configurable.

ACCURATE MOISTURE MEASUREMENT INCREASES PROFITS AND PROVIDES CONTROL

Pulp industry standards require the precise determination of the actual percent moisture content and/or Air-Dry Weight of each shipment.

Accurate moisture determination has a direct effect on pulp mill invoicing and bottom-line profits. Pulp that is too wet will cause customer complaints, so some mills under-invoice to ensure customer satisfaction. However, pulp that is too dry wastes energy and can also cost your company profits due to under-billing.

Laboratory oven drying methods, which measure less than 0.001% of your production, inherently have significant sampling errors and can make accurate invoicing impossible. Since these tests often take hours to complete, they are useless for controlling energy consumption. Forté's measurement occurs instantaneously, at the bale press, so the information is gathered within minutes and can be used to adjust dryer controls more effectively.

Forté Measures Every Bale Automatically – in the Press

Forté's patented method measures the moisture in all of your production. Every sheet in every bale is measured – totally & automatically – in real time - while the bale is being pressed. The entire bale – every bale – is measured.

Only Forté provides 100% sampling and the direct means to improve yield by 1/2% or more. Even a 100 tons per day mill can realize a return of \$1,000/day or more.

Return on Investment (ROI) for a Forté System occurs in weeks rather than in years.

How the Forté System Works

The secret of each Forté System is in its electrode sensor and signal generator. The Forté electrode passes a harmless, low-power electronic field through your entire bale.

In the bale press system, the electrode is attached to your bale press platen. The weighing station may be located either before or after the bale press. For non-press measurements, a test cell is mounted astride the conveyor and the reading is obtained at normal conveyor speed. In either case, this exclusive patented 2-step measurement is self-zeroing and virtually instantaneous.

The Forté System is calibrated using laboratory oven tests. Our experienced engineers will assist with this at the time of installation. Once a careful calibration is completed, the Forté System can operate effectively for many years. In fact, some systems have been in continuous use for up to 30 years.

Hardware

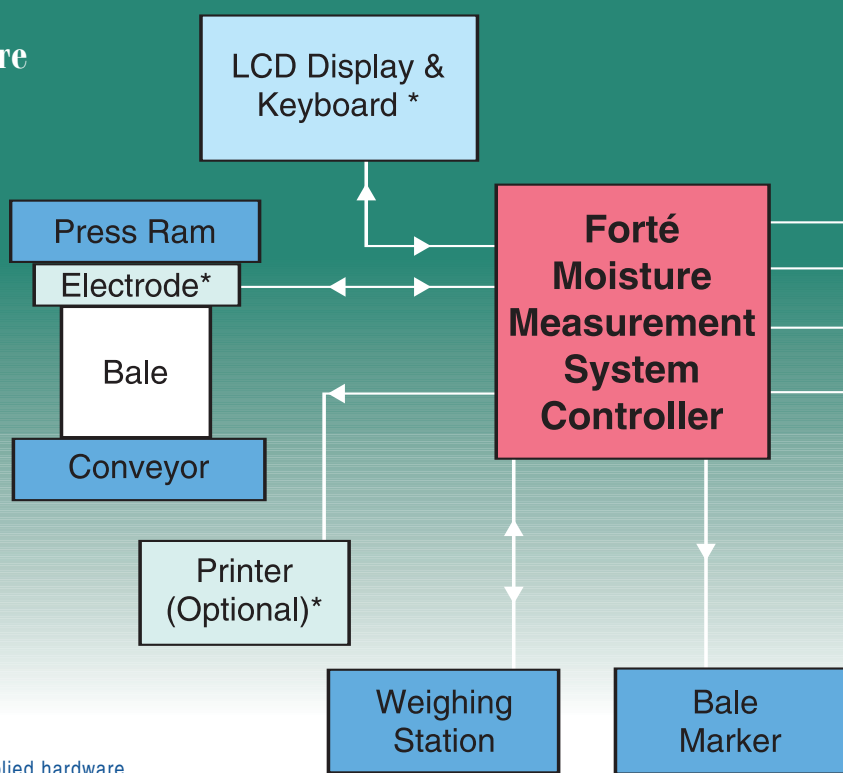

Connectivity

* Forté supplied hardware

Forté 8000 Series

Features of the Forté 8000 Series Include:

- User-friendly Windows Menus
- Network Connectivity
- Archives 24 Months of Bale & Lot Records
- Data Output to SQL Server
- Multi Language Versatility
- Application Security Independent of Windows Security
- Improved Diagnostics and Automatic Failure Detection
- User-configurable Views and Reports
- Expandability

Options:

- Bale Marking
- Basis Weight
- Quality Input
- Automatic Grade Input
- Unit Processing
- Rebale
- Drop Control
- Analog Output
- Large LED Display

The Forté controller receives the electronic moisture reading and the digital weight input. These numbers, together with the appropriate calibration constants for the product being measured, are used to calculate the % Air-Dry.

User-configurable on-screen reports display measurement and other data such as:

Time, Date, Stock, Grade,
Bale Number, Lot Number,
Gross Bale Weight, % Air-Dry (Moisture),
true Air-Dry (Invoice) Weight, etc.

Alternative "tab" views include:

Bale, Lot, Shift, Day, and
Quality Summaries in addition to
Prior Totals.

On-screen alarms alert the user to any communication errors or out-of-limit bale data.

Forté Provides All the Information You Need

A record of each measurement and its associated data is stored in our archives. Production data for the last 24 months can be viewed and/or printed.

An Ethernet connection can be used to transmit this valuable data to your mill-wide information system. A shared file is often utilized so that the security issues of a direct network connection are nonexistent. In addition, if a problem occurs on your network, your Forté System will still function.

Remote indicators and video displays, wet/dry and heavy/light alarms, and automatic Layboy drop control systems are available as options. Data transmission in serial form can be output to label printers and stencillers/bale markers.

The Forté System can even be expanded to include quality data such as brightness, dirt count, shives, and viscosity. This information can be entered manually or input automatically from your existing devices.

All of these features are available for a fraction of the cost of a scanner.

How Forté Can Help You

Conventional testing for moisture is neither practical, nor accurate. With a Forté System, you can know the exact moisture content of all of your production within minutes.

No matter what size operation you have, a Forté System can be configured to fit your needs. Let Forté design a system to increase profits in your mill.

Remote Profile

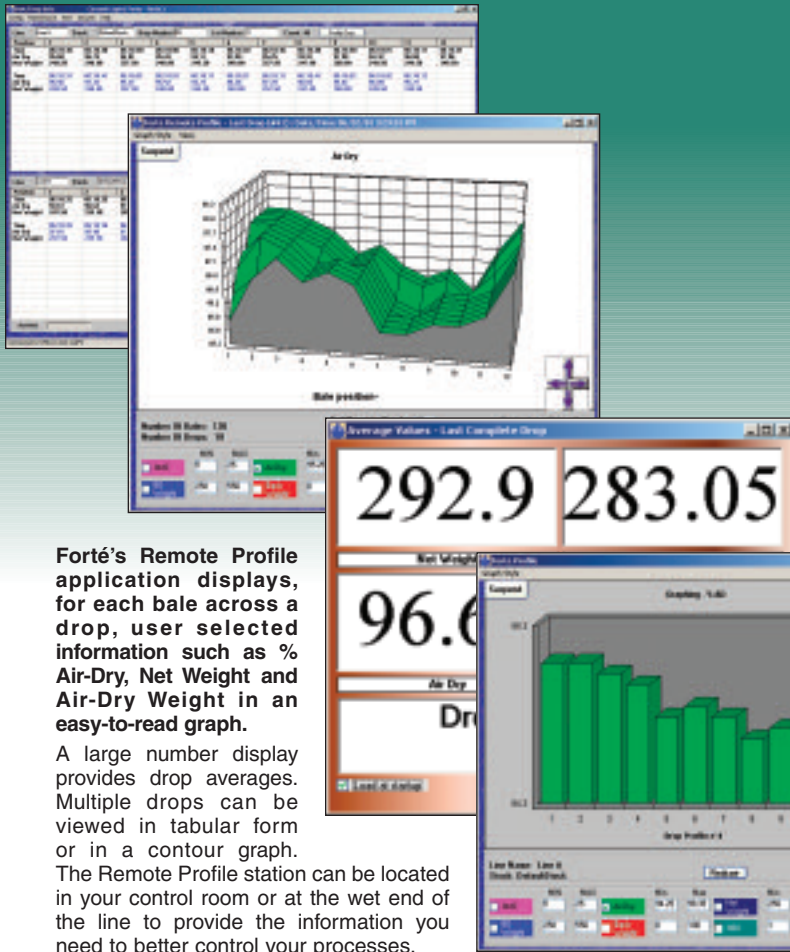

Forté's Remote Profile application displays, for each bale across a drop, user selected information such as % Air-Dry, Net Weight and Air-Dry Weight in an easy-to-read graph.

A large number display provides drop averages. Multiple drops can be viewed in tabular form or in a contour graph.

The Remote Profile station can be located in your control room or at the wet end of the line to provide the information you need to better control your processes.

FTrends

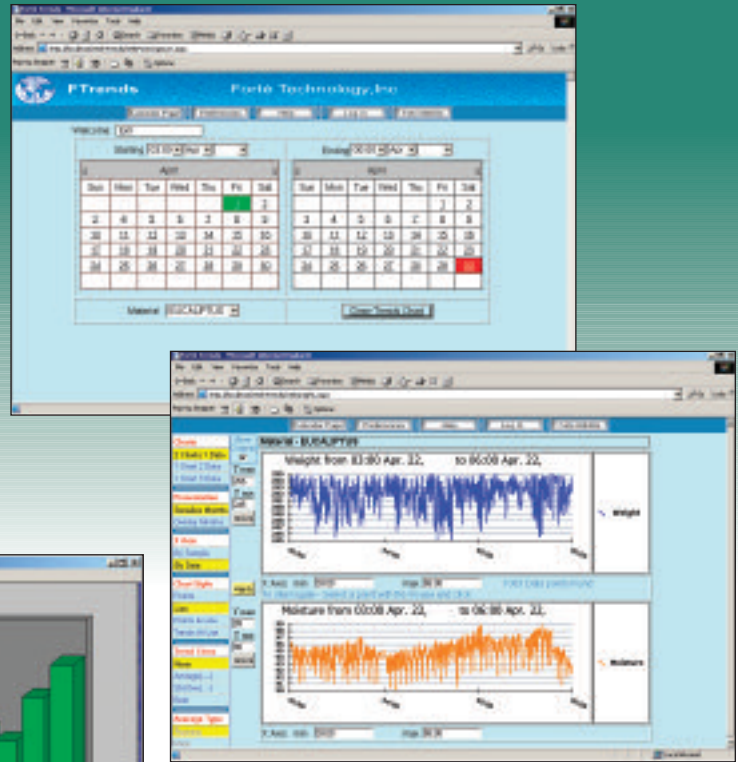

Forté's FTrends application allows the user to graph selected information by date over time.

It is a web-based application that can be accessed from any networked computer. Multiple users can view simultaneously. It can be a useful tool in comparing production records from shift-to-shift, day-to-day, and even month-to-month or year-to-year.

Advantages of the Forté System:

- Generates Additional Profits - Increases Tons Billed
- Improves Accuracy by 100% Sampling – Measures Every Bale
- Measures Moisture in Real Time – Not Hours Later
- Allows Maximizing Invoice Levels without Risk of Customer Complaints
- Lowers Energy Costs – Optimizes Drying vs. Shipping Costs
- Reduces Testing and Production Labor
- Improves Quality
- Provides Accurate Production Records
- Enables Monitoring of Pulp Moisture to Reduce Frequency of Web Breaks
- Archives and Prints Production Data Records



"Your Partner for Profit"

Forté Technology, Inc. has been the world leader in moisture and weight measurement since 1958. Systems are now located in over 40 countries throughout the world.

Forté

TECHNOLOGY INC.

201 Carnegie Row, Norwood, MA 02062 U.S.A.

TEL. 1 781 769 9150 FAX. 1 781 769 5308

e-mail: info@forte-tec.com Website: <http://www.forte-tec.com>